

# GLE/GTAS/001 GPS Tracking Antenna System

## Features

- Embedded IRIG 106 PCM Decoder
- Real-time tracking calculation with trajectory interpolation
- Real-time display of tracking parameters
- Local or remote configuration
- Optional internal Bit-Synchronizer
- Optional GPS/Magnetometer for local reference



## Introduction

GLE/GTAS/001 is a system designed to control the angular position (*Azimuth / Elevation*) of one or more ground tracking antennas used to receive telemetry data from an aircraft during flight testing activities.

To fulfil this task it utilizes GPS position data embedded in the PCM telemetry stream, transmitted by the aircraft FTI system in combination with the GPS coordinates of the receiving antenna or antennas.

## System Description

GLE/GTAS/001 incorporates an IRIG 106 ch. 4 PCM telemetry decoder for Data+Clock PCM streams and optionally a bit synchronizer for Bi-Phase, NRZ-L and RNRZ-L (9/11/15/17/23) codes; supported data-rate is  $\leq 10$  Mbps\*.

Its data processor runs real time algorithms to compute the necessary antenna azimuth and elevation angles to achieve the continuous tracking of the aircraft.

Tracking algorithms include interpolation of the aircraft speed and position in order to cope with short interruptions in the telemetry link.

Angular data are sent to the tracking antennas via RS-232 lines using ASCII protocol\*\* with an update rate up to 8 Hz.

Optionally a GPS receiver can be embedded into the system and an external magnetometer/compass can be connected as a local reference for a mobile tracking antenna.

\* On request it is possible to support up to 20Mbps, contact factory for additional details

\*\* Different serial protocols can be supported on request

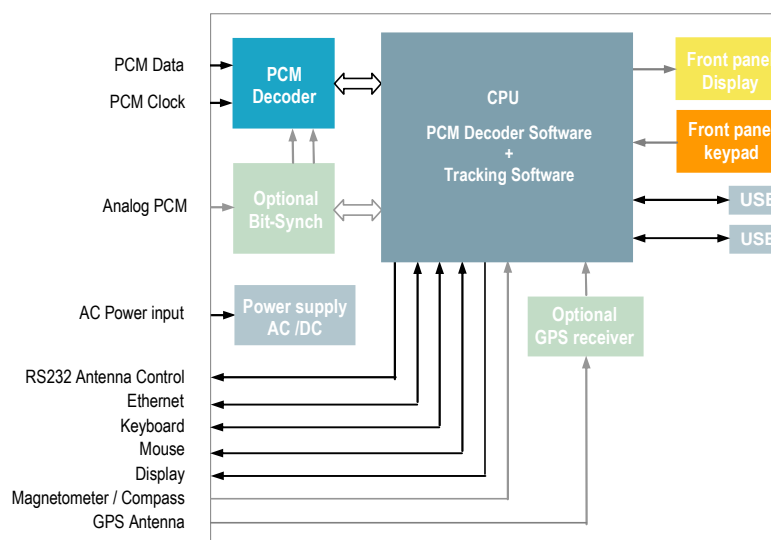

## System Setup

The software GUI allows the user to define PCM decoder setup, PCM frame structure, position of the GPS parameters inside the PCM frame, GPS coordinates of the receiving antenna and the initial antenna pointing angles to establish the telemetry link.

Multiple predefined setups can be stored and quickly retrieved to/from an internal non volatile memory.

## User interface

Control and setup of the system can be done in different ways:

- via a front panel alphanumeric display and a keypad that allows the main operations; 4 LEDs provide quick status information;
- by connecting a standard keyboard, mouse and VGA display set (*interfaces are available on the rear panel*);
- by remote, via Ethernet interface, with a web based graphical interface;
- different setups can be copied between GLE/GTAS units, by means of the front panel interface and a USB stick.

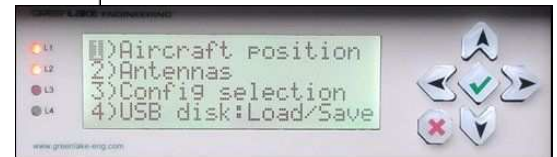

## I/O data interfaces

- n° 6 RS-232 Ports: for controlling up to 6 antennas with ASCII serial protocol;
- n° 1 Ethernet Port: for remote control or for controlling antennas with Ethernet protocol;
- n° 1 PCM Input Port: available with TTL and RS-422.

## General Specifications

- GLE/GTAS/001 has been designed for the following environmental condition.
- Temperature: operating 0 ÷ +50°C / storage -40 ÷ +70°C.
- Humidity: 0 ÷ 80% relative, non condensing.
- Altitude: 0 ÷ 2.700 m.
- EMI: assembled with subcomponents complying with EN55011, EN50081 and EN50081.
- Power Requirement: 115 / 230 VAC - 50 / 60 Hz - (< 200 Watt).
- Size: 19" x 2U x 340 mm, rack mountable chassis.
- Weight: about 10 kg, depending on specific options.

## Possible options

- Built-in Bit-Synchronizer.
- PCM input data rate up to 20 Mbps.
- Built-in GPS receiver + external GPS antenna and magnetometer/compass, as local reference for a mobile tracking antenna.

*This product is not intended for use in applications whose its failure to perform can be expected to cause damages to properties and/or persons and/or injury to human life. Due to continuous developments, specifications are subject to change without prior notice.*

GreenLake Engineering Srl  
 the engineering branch of Instrumentation Devices  
 Via Acquenera 29 22100 COMO – Italy  
 ph: +39.031.525.391 - fax: +39.031.507.984 - info@greenlake-eng.com

[www.greenlake-eng.com](http://www.greenlake-eng.com)

