

GLE/RMVC-200-U

Ruggedized Miniature Video Camera for Harsh Environments.

Applications

- Flight testing Instrumentation in non-conditioned / dark bays (i.e. engine nacelles / landing gear bays).
- Video monitoring / surveillance in Harsh Environments.

Main Features

- Environmentally protected
- Integrated LED illuminator
- Heated shatterproof lens windows
- Rugged construction, one piece camera, no external control box
- Color CVBS output
- 2000 Lux sensitivity (@F11 AGC: 0dB)
- Wide dynamic range and excellent SNR
- Noise Reduction Function
- Automatic and Manual White Balance
- High speed shutter control
- Electronic image rotation and mirroring
- Setup via RS232 interface with software GUI
- Extended operating temperature range
- Wide DC voltage supply range



Overview

GLE/RMVC-200-U is a miniature and rugged standard definition color video camera.

It is designed for on-board testing and instrumentation applications in non-conditioned / dark bays where exposure to moisture, ice and low temperature is expected.

Derived from GLE/RMVC-200v2, it is based on a well proven, high quality 1/3 inch Charge Coupled Device (CCD), installed in an EMI shielded, harsh-environment-tight aluminum precisely machined enclosure.

This camera provides 460/470 television lines of resolution; the integrated electronic

shutter/CCD IRIS can operate up to 1/100000 s.

Its use is very simple, no external control box is required, the user can remotely control via standard RS 232C various functions such as Shutter Speed, Red/Blue level, Pedestal, Image Rotation and Mirroring, AGC, CCD IRIS, etc. Its "U" shaped body includes a high efficiency LED illuminator and the optics in a compact design.

Both the camera and illuminator lens windows are provided of self regulated heating element to prevent fogging and icing. A humidity filter prevents condensation inside the body.

A series of precision mounting holes, strengthened by stainless steel Heli-Coil® threaded inserts, makes simple the installation. This camera, designed having MIL-STD specification in mind, ensures safe operation and correct performance, under severe mechanical conditions, in an extended temperature range and in a wide DC voltage supply range. The exceptional rugged construction, miniature size, lightweight and high image quality make this camera suited for the most demanding applications in space-restricted and severe environment conditions.

Setup software GUI

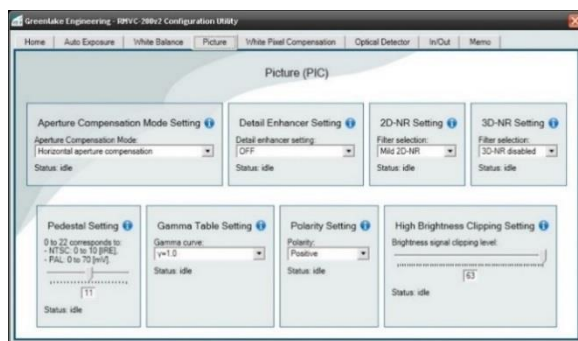

A software GUI for MS-Win is supplied for the setup of the camera functions via RS232.

Due to continuous developments, specifications are subject to change without prior notice. This product is not intended for applications whose its failure to perform can be expected to cause damages to properties and/or persons and/or injury to human life.

GreenLake Engineering Srl
the engineering branch of Instrumentation Devices
Via Acquanera, 29 - 22100 COMO - Italy
+39.031.521.076 - info@greenlake-eng.com



Main Characteristics

Video System	PAL Version : GLE/RMVC-200-U-P	NTSC Version : GLE/RMVC-200-U-N
Sensor device / Colour filter	1/3 type IT CCD / Complementary colour mosaic	
Effective picture elements	752 (H) x 582 (V)	768 (H) x 494 (V)
Scanning system	625 lines, 2:1 interlace, 25 frames/sec	525 lines, 2:1 interlace, 30 frames/sec
Optics	Focal Length (f) 2.7 mm / F number 1 : 1.8 Aperture: F1.8 to F11 / Angle of view: 100.8 deg. (H), 75.5 deg. (V) / Shortest range: 10 cm Protection window: heated shatterproof neutral lens	
Video output	CVBS: 1Vp-p, 75 Ohm, sync negative	
Horizontal resolution	460 TV lines	470 TV lines
Minimum illumination	1.5 Lux (@F1.4 AGC:18dB)	
Sensitivity	2000 Lux (@F11 AGC:0dB)	
Signal Noise Ratio	46 dB (AGC OFF (0 dB))	48 dB (AGC OFF (0 dB))
Shutter speed	Fixed (from 1/50 to 1/100000s) or auto IRIS	Fixed (from 1/60 to 1/100000s) or auto IRIS
CCD IRIS range (*)	Selectable from 1/100s to 1/100000s	
White balance	5 modes selectable: ATW, One Push WB, 3200 K, 5600 K, MANUAL	
Gain control	Selectable: AGC or Fixed (from -3 dB to +18 dB)	
Illuminator	Lamp type: LED / Light colour: white / Light cone angle: 110 deg. Protection window: heated shatterproof neutral lens Control: via serial terminal emulator (e.g. Hyperterminal), selectable from 0 (off) to 10 (full power).	
Heating	Resistive elements. Independently digitally controlled temperature, on the optics and on the illuminator protection windows. Control: via serial terminal emulator (e.g. Hyperterminal), set points selectable from 0 to 70C°.	
Power requirements	2 independent inputs: Video camera + LED illuminator: 28 VDC (18÷32 VDC) / 3.5 W (@28VDC); Heather: 28 VDC nominal / 10 W (heating on).	
Electrical connections	PTFE coated shielded cables through a polyamide cable gland.	
Environment	Shock & Vibration: designed to meet MIL-STD 810F Temperature: operating -40 ÷ +65° C (-40 ÷ +149 °F) (tested). Protection grade: IP65 (LED and Optics heads)	
Enclosure	Milled Anticorodal aluminum, anti-reflective black anodized; provided with humidity filter and protective shatterproof lens.	
Weight	Approx. 550g (19.4 oz.) with 2 meters cables	

(*): Max speed is not guaranteed beyond 1/4000 s.

Mechanical Drawing

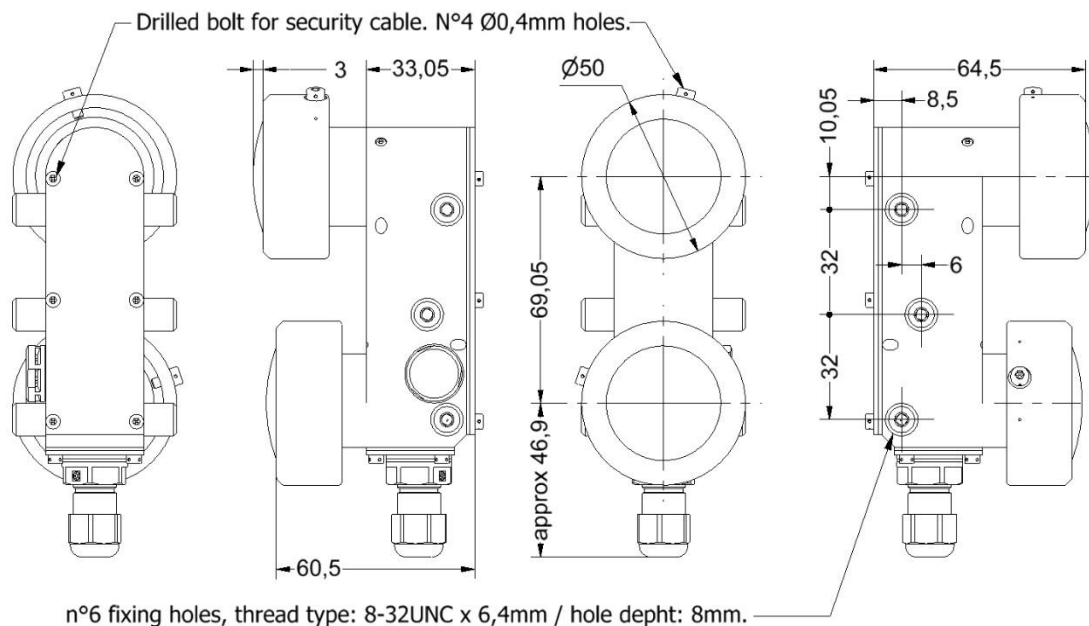

Due to continuous developments, specifications are subject to change without prior notice. This product is not intended for applications whose its failure to perform can be expected to cause damages to properties and/or persons and/or injury to human life.

GreenLake Engineering Srl
the engineering branch of Instrumentation Devices
Via Acquanera, 29 - 22100 COMO - Italy
+39.031.521.076 - info@greenlake-eng.com

